

## **Determining the Moderating Role of Supervisor's Support, Peer's Support, Opportunity to Perform Between Perceived Training Utility and Transfer of Training**

Kamran Iqbal

*Bahria University, Pakistan*

### **Abstract**

*The purpose of this study was to examine how perceived training utility influences transfer of training. Also, how this relationship was affected by existence of Supervisor's support, Peer's support and opportunity to perform in the context of banking sector employees. Sample for this study (n = 215) was drawn from employees working in banking sector of Pakistan through purposive non probability sampling technique. SPSS software was used to extract the information from the collected data. The results of regression analysis indicated that perceived training utility is positively related to training transfer. The results also suggested that Supervisor's support, Peer's support and opportunity to perform moderate the relationship between perceived training utility and transfer of training. These results highlighted the importance of perceived training utility for effective transfer of training and suggest that transfer of training can be improved through increase in Supervisor's support and Peer's support and opportunity to perform.”*

**Keywords:** Transfer of training; Perceived training utility; Supervisor's support; Peer's support

### **Introduction**

High competition has been observed among the organizations due to rapid changes in technology and economic forces. Continuous improvements in product and services are required in order to survive in such a competitive environment (Kueng, 2000). These drastic changes have made skilled employees as main source of competitive advantage for all organization has made human resource (Drucker, 1999). Although technology, good will, human resource and quality of product, all contribute towards competitive advantage but it is very difficult for organization to imitate the human resource of other organization. In order to gain competitive advantage and to compete in environment of global competition, organizations has been investing huge money to develop their employees( Kauffeld & Lehmann-Willenbrock, 2010; Van Buren& Erskine, 2002). Trainings are considered as reliable technique to increase organizational productivity and to develop human resource (Bhatti & Kaur, 2009). Dean et al. (1996) also indicated in his research the role of trainings in employee's performance. Arthur et al.( 2003) pointed that trainings are conducted with the intention to achieve desired outcomes. Although organizations has increased average training hours per employee (Heathfield, 2009) and

investments on trainings has also increased (Blandy et al., 2000) but trainings efforts were found to be less productive i.e. Burke and Hutchins (2007) observed that only 10 to 40 % trainings material transferred to actual job. .

Montesino, (2002) indicated that training efforts cannot contribute to employees performance unless employees do not apply learned KSA (Knowledge, skills and abilities) on their job. Holton & Baldwin (2003) recommend researchers to examine the factors related to transfer of training. Transfer of training has been defined as “the extent to which knowledge and skill acquired in a learning setting can be applied in the workplace, and maintained over time (Blume et al., 2010)”. In training First step is the learning of training contents and second step is the transfer of learning contents on actual work (Noe et al., 2006). So It is necessary to understand the factors that affect transfer of training so that transfer rate could be increased. Research conducted on transfer of training mainly focus on extracting the factor related to transfer of training but in the current paper author proposed and tested the moderating effect of Supervisor's support, Peer's support and opportunity to perform in relationship between perceived training utility and transfer of training. The researcher has started first to checked the direct effect of perceived training utility on transfer of training and (i.e., is perceived training utility effects transfer of training?), then proposed and checked the possibility of Supervisor's support, Peer's support and opportunity to perform as moderator between main effect and transfer of training

The objectives of this research are

- To investigate the relationship between perceived training utility and transfer of training.
- To investigate whether Supervisor's support, Peer's support and opportunity to perform moderate the relationship of perceived training utility and transfer of training.

## **Perceived Training Utility**

Training utility is considered as important element while studying transfer of training. Perceived training utility has significant affect on transfer of training (Burke & Hutchins, 2007). Chiaburu & Lindsay, (2008) pointed that perception of trainees about the utility of training mainly depend on relationship between trainings and expected performance or outcomes. “Velada et al. (2007) indicated that perceived training utility depend on application of training contents and degree to which training contents are related to work. Researchers also found relationship between Perceived training utility and training motivation i.e. Clark et al. (1993) found direct relationship between motivation and trainee's perception about training that it will lead to job or career utility. Career utility was defined by Clark et al. (1993)” “as the perceived usefulness of training for attainment of career goals, such as getting a raise or promotion, or taking a more fulfilling job” and Job utility “as the perceived usefulness of the training course to facilitate goals associated with the current job, such as increased productivity, reduced errors, or better problem-solving skills”. Burke & Hutchins (2007) highlighted few factors that contribute to perceived training utility, understanding of performance gap that can be filled through

training, credibility of training material learned through training and finally trainee's perception about how ease is transfer of training.” Chiaburu & Lindsay (2008) conducted his research related to transfer of training on employees of big organizations in service sector of united state of America and observed strong relationship between perceived training utility and transfer of training. In Meta analysis about transfer of training, Alliger et al. (1997) found perceived training utility as main predictor of transfer of training. Lieberman & Hoffmann (2008) also observed the significant impact of utility expectation about training and transfer of training. Grossman & Salas (2011) found linkage between training utility and transfer motivation that ultimately lead to transfer of training. Expectancy model could be useful to understand motivation factor that significant effect on process of training transfer (Baldwin & Ford (1988). Expectancy model proposes positive relationship between effort and performance. Individuals put their maximum efforts only when they expect by putting their effort, they will achieve desired performance level and that performance level will give them desired rewards and outcomes (Kontoghiorghes, 2001). An individual put efforts when he expects positive outcomes, and if person lacks in positive expectation, it would be rare that he will put efforts for performance improvement (Vroom, 1964). The concept of perceived training utility can be understand with the help of expectancy theory. Clark et al. (1993) pointed that when trainees perceive that training transfer will lead to valuable outcomes i.e. career progression or performance improvement, their motivation to transfer is increased. Trainees with positive expectation from particular training were more motivated to apply their knowledge and skills on actual work (Grossman & Salas, 2011).

### **Supervisor's Support**

Supervisor support is defined as “the extent to which the supervisor behaves in a way that optimizes employees' use on the job of the knowledge, skills and attitudes gained in training” (Nijman et al., 2006). Supervisor's attitude and behavior has considerable impact on transfer of training. Managers usually support his employees in training in the form of giving permission for participation in training programs and also sometimes he participates as trainer in training program employees (Birdi et al., 1997; Burke & Baldwin, 1999). Goldstein and Ford (2002) pointed that supervisor's role is essential for effectiveness of trainings. Supervisor's should be included both planning and preparation phase of training programs (Bader & Bloom, 1995). Role of supervisor's support in transfer of training and significant impact of supervisor's support on motivation to transfer has found in many studies (Chiaburu & Tekleab, 2005; Chiaburu & Marinova, 2005; Facticeau et al., 1995; Gregoire et al., 1998 & Velada et al., 2007). When supervisor and co-workers encourage employees to learn new skills and apply these skills on job, it increases transfer of training (Tracey et al., 1997). When employees perceived that their supervisor encourage the use of new learned KSA's, most likely that they will apply learned knowledge and abilities on actual work (Colquitt et al., 2000; Tracey & Tews, 2005)

### **Peer's Support**

Hawley & Barnard (2005) pointed that if employees interact with their peers regarding the application of learned skills, more chances that they will apply learned skills on their

job. "Peer support has defined by Holton et al. (1996) as the extent to which peers reinforce and support the use of learning on the job". Support of top management, support of supervisor, support of peers, and support of subordinates, all are required for successful transfer of training Baldwin & Ford, 1988). Hatala and Fleming (2007) pointed that Peer's support contribute in transfer of training in number of ways i.e. by giving assistance in deriving solution of a problem, through sharing information and by giving productive feedback about their performance. Gilpin-Jackson & Bushe (2007) pointed that colleague's support may have impact on transfer of skills more than the impact of supervisory support on transfer of skills. Chen (2007)" also highlighted the significant role of top management and peers in effectiveness of training programs. Peer's support also have strong linkage with motivation to transfer (Kirwan & Birchall, 2006). "Nijman et al. (2006) suggested that peer's behavior in term of support and motivation maximize transfer of training. Later on Holton et al. (2007) indicated the significant role of peer's support on post training behaviors as compare to role of other social factors. Holton et al. (2003) indicated that peer's support not only contributes in transfer of training but their negative behaviors can create hurdles in transfer of training."

## **Opportunity to Perform**

Opportunity to perform can be taken as kind of support when concept of transfer of training is considered (Lime & Johnson, 2002). Grossman & Salas (2011) pointed that trainees take opportunity to perform as essential element for transfer of training and lack of opportunity to perform discourage individual to transfer learned skill on job.

Burke & Hutchins (2007) also pointed that for effective transfer of training, employees must be give opportunities to use their newly developed skill on work. Limited opportunities to perform inhibit employees to apply learned KSA's on work and are barrier towards transfer of training (Clarke, 2002). Salas et al. (2006) pointed that time period gap between training program and opportunity to perform should be diminish, can be big obstacle in transfer of training.

Grossman & Salas (2011) indicated that organizations should create opportunities for trainees to apply learned KSA's on job by giving them required time and resources i.e. supervisor can adjust workload of fresh trainees in order to give them more opportunities for utilization of new learned knowledge and skills. Salas & Stagl (2009) pointed that organizations should not take end of trainings as the formal ending of training programs. In the end of training, there should be practice and discussions, review on actions and feedback to increase transfer of training (Baldwin et al., 2009).

**H1:** There is positive relationship between perceived training utility and transfer of training.

**H2:** Relationship between perceived training utility and transfer of training is moderated by supervisor's support such that relationship is stronger in the presence of moderator transfer climate.

**H3:** Relationship between perceived training utility and transfer of training is moderated by peer's support such that relationship is stronger in the presence of moderator transfer climate.

**H4:** Relationship between perceived training utility and transfer of training is moderated by opportunity to perform such that relationship is stronger in the presence of moderator transfer climate.”

## Theoretical Framework

Theoretical framework is as follows:

**Figure 1:** Theoretical Framework

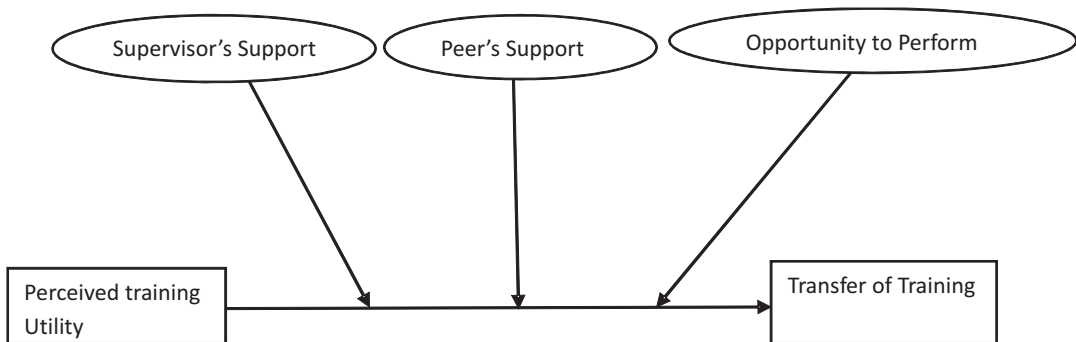

## Methodology

The population of the present study was the employees working in banking sector in Rawalpindi & Islamabad. Initially about 300 Questionnaire were distributed, through personally administered and out of 300 near 240(80%) were return back. Out of returned questionnaires only 215 were used for final analysis which was 72% of the distributed Questionnaires. Because few questionnaires were returned blank, few were half filled, and in few questionnaire there was double entry which made those questionnaire unfit for analysis. Data was collected with the help of self-administered Questionnaires. The sampling method used current study was non probability judgmental sampling due to nature of the study.

The Questionnaire of transfer of training was adopted from Xiao (1996). The Questionnaire consist of 6 items i.e. “I can accomplish the tasks better by using the new knowledge acquired from the training course”. The Questionnaire of peer's support was adopted from Jones, (1986). The Questionnaire of supervisor's support was adopted from Jones, (1986). The questionnaire consists of 6 items shown in Table 1.

**Table 1:** Items of Questionnaire

Variables	No of items	Alpha Reliability Coefficients
Perceived training utility	6	.756
Supervisor's support	6	.865
Peer support	2	.815
Opportunity to perform	6	.708
Transfer of training	6	.622

## Results and Discussion

### Reliability analysis

The reliability coefficients of all the scales used in this study are given in the table. All reliability coefficients are within the acceptable range (Kline, 2000). The maximum reliability is of supervisor's support (.865), and minimum reliability is of transfer of training (.622).”

### Confirmatory Factor Analysis

Confirmatory factor analysis (Figure 2) was employed by using AMOS statistical package in order to evaluate and refinement of the proposed measurement model and to verify the distinctiveness of variables as recommended by (Gerbing and Anderson, 1988). Overall, results of the CFA exhibited a good fitness of the model with ( $\chi^2=243.911$ , degrees of freedom (df)= 124,  $p=0.00$ , GFI= .888, AGFI= .849, , CFI= .920, RMSEA=.067. the results of CFA shows that PTU is adequately measured with four items, Supervisor's support with six, Peer's support adequately measured with two items, Opportunity to perform with three items, while Transfer of training is adequately measured by using three items.

Figure 2: Results of CFA

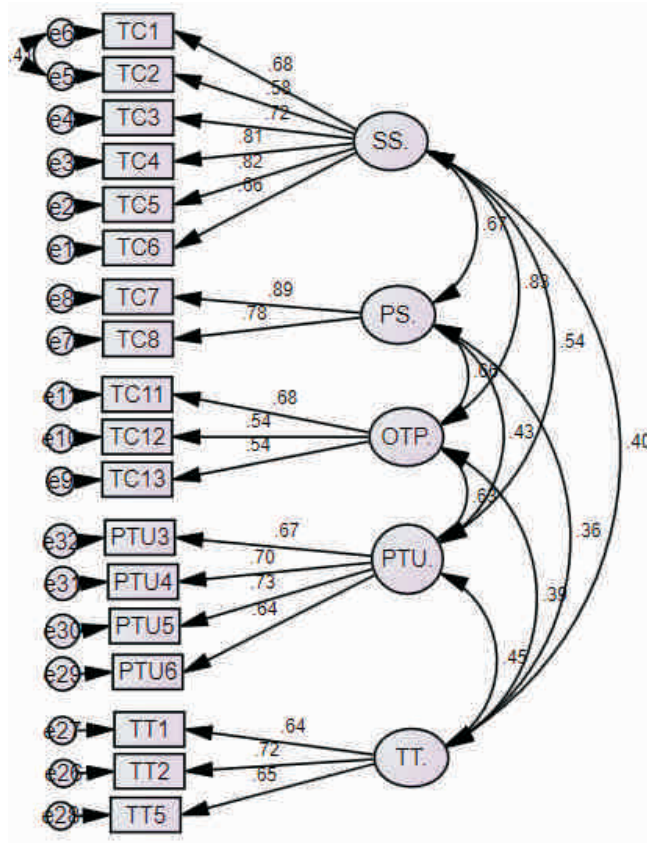

**Table 2:** Results of CFA (Fit measures)

	Chi-Square	DF	p value	CMIN/DF	GFI	CFI	AGFI	RMSEA
Values	243.911	124	.000	1.967	.888	.920	.849	.067

## Correlation

Correlation matrix shows the level of association between the different variables used in the current study. Result shows the significant correlation between all variables. Correlation between the each pair of independent variable is below .80, which minimize the chance of multicollinearity in the current data.

**Table 3:** Correlation matrix

	PTU	SS	PS	OP	TT
Perceived training utility	1				
Supervisor's support	.453**	1			
Peer support	.307**	.556**	1		
Opportunity to perform	.290**	.399**	.414**	1	
Transfer of training	.246**	.333**	.212**	.167*	1

\* Correlation is significant at the 0.05 level (2-tailed)  
 \*\* Correlation is significant at the 0.01 level (2-tailed)

## Regression Analysis

Transfer of training is regressed on perceived training utility. In order to analyze the data beta and R2 are used. Result shows the significant impact of perceived training utility on transfer of training (B= .246, R2 = 24.6, p< .001). R square shows that it is a very good model as it explains 24.6% variation in dependent variable. Beta value shows that by changing one unit in PTU, TT will be changed by 246. So hypotheses 1 is accepted.

**Table 4:** Results of Regression

	B	R <sup>2</sup>	Significance
Perceived training utility	.246	24.6	.000

\***Predictor:** transfer of training

In order to check the moderating effect of supervisor's support in the relationship between perceived training utility and transfer training. In first step, 'transfer of training' is regressed on perceived training utility and supervisor's support. In second step transfer of training is regressed on interaction term of PTU and SS along with PTU and SS. Results show interaction term have significant impact on transfer of training. Beta value of the relationship between supervisor's support and perceived training utility is .120 which becomes 1.696 when transfer of training is regressed on interaction term. So from these results we can conclude that supervisor's supports moderate the relationship between perceived training utility and transfer of training. So H2 is accepted.

**Table 5:** Results for mediating analysis

	B	R <sup>2</sup>	R <sup>2</sup>	Significance
<b>Step 1</b>				
Perceived training utility	.120			.097
Supervisor's support	.278	.122		.000
<b>Step: 2</b>				
Perceived training utility	-.690			.002
Supervisor's support	-.870			.005
Interaction term	1.696	.181	.058	.000

\***Predictor:** transfer of training

In order to check the moderating effect of Peer's support in the relationship between perceived training utility and transfer training. In first step transfer of training is regressed on perceived training utility and Peer's support. In second step transfer of training is regressed on interaction term of PTU and PS along with PTU and PS. Results show interaction term have significant impact on transfer of training. Beta value of the regression between Peer's support and transfer of training is .190 which becomes .198, when transfer of training is regressed on interaction term. Results shows that Peer's support moderate the relationship between perceived training utility and transfer of training. So hypotheses H3 is accepted.

**Table 5:** Results for mediating analysis

	B	R <sup>2</sup>	$\Delta R^2$	Significance
<b>Step 1</b>				
Perceived training utility	.205			.002
Opportunity to perform	.081	.071		.133
<b>Step 2</b>	6.013			.000
Perceived training utility	-.751			.003
Opportunity to perform	-.905			.000
<b>Interaction term</b>	.271	.131	.066	.000

\* **Predictor:** Transfer of training

## Implications

Apart from many theoretical implications, the results highlighted in this study also have substantial practical implications for the organizations. While developing policies for their human resource, organizations must consider the elements highlighted in current research. This research recommends that if organizations want to enhance transfer of training and want to get maximum benefits out of their heavy investment, they should try to create supportive environment where trainees are given opportunities to apply learned KSA's, peer's support and supervisor also supportive toward trainees. Results also demonstrate that organizations should design trainings in such a way that would beneficial for trainee's current performance and beneficial for their career growth. Also

trainees should communicate well regarding benefits of particular training. This will enhance their motivation and ultimately will increase transfer of training.

## Limitations of the Study and Future Research

In current study respondents were the employees of banking sector of Pakistan. The results of this study cannot be generalized as banking sector only represents service industry. Future researchers can test the model of current study in other industries. This study tested the moderating role supervisor's support, peers support and opportunity to perform between perceived training utility and transfer of training. Future research can be conducted to test the moderating role of other variable i.e. job satisfaction. This study, we used cross-sectional research design. But in order to get more reliable results, other researchers should use longitudinal research design. Also this study was conducted in Pakistani context. Future researcher may test this model in the western context to confirm the results. Data on transfer of training was measured using self-report measure, which suggests the possibility of common method bias. Therefore, it may be assumed that the results of this research too were influenced by common method bias. Finally, this study was conducted in a single, banking sector, which limits the possibility of generalizing its conclusions to other sectors.

## References

- Alliger, G.M., Tannenbaum, S.I., Bennett, W. Jr, Traver, H. & Shotland, A. (1997). A meta-analysis of the relations among training criteria. *Personnel Psychology*, 50(2), 341-358.
- Arthur, W., Bennett, W., Edens, P.S. & Bell, S.T. (2003). Effectiveness of training in organizations: a meta-analysis of design and evaluation features. *Journal of Applied Psychology*, 88(2), 234-45.
- Awoniyi, E.A., Griego, O.V. & Morgan, G.A. (2002). Person-environment fit and transfers of training. *International Journal of Training and Development*, 6 (1), 25-35.
- Bader, G.E. and Bloom, A.E. (1995). *Make your Training Results Lasts*. London: Kogan Page.
- Baldwin, T. T. & Ford, J. K. (1988). Transfer of training: a review and directions for future research. *Personnel Psychology*, 41, 63-105.
- Baldwin, T. T., Ford, K. J. & Blume, B. D. (2009). Transfer of training 1988-2008: an updated review and agenda for future research. *International Review of Industrial and Organizational Psychology*, 24, 41-70.
- Bhatti, M.A. & Kaur, S. (2009). Factors effecting transfer of training: a fresh review", paper presented at the 12th International Business Information Management Conference, (IBIMA), Kuala Lumpur.
- Birdi, K., Allan, C. & Warr, P. (1997). Correlates and perceived outcomes of four types of employee development activity. *Journal of Applied Psychology*, 82 (6), 845-57.

- Blandy, R., Dockery, M., Hawke, A. & Webster, E. (2000). *Does Training Pay?*, National Centre for Vocational Education Research, Leabrook.
- Blume, B.D., Ford, J.K., Baldwin, T.T. & Huang, J.L. (2010). Transfer of training: a meta-analytic review. *Journal of Management*, 36 (4), 1065-105.
- Burke, L.A. & Baldwin, T.T. (1999). Workforce training transfer: a study of the effect of relapse prevention training and transfer. *Human Resource Management*, 38 (3), 227-42.
- Burke, L.A. & Hutchins, H.M. (2007). Training transfer: an integrative literature review. *Human Resource Development Review*, 6 (3), 263-96.
- Chen, C.-Y. (2007). Exploring potential factors leading to effective training. *Journal of Management Development*, 26 (9), 843-56.
- Chiaburu, D. S. & Lindsay, D. R. (2008). Can do or will do? The importance of self-efficacy and instrumentality for training transfer. *Human Resource Development International*, 11, 199–206.
- Chiaburu, D.S. & Tekleab, A.G. (2005). Individual and contextual influence on multiple dimensions of training effectiveness. *Journal of European Industrial Training*, 29(8), 604-26.
- Chiaburu, D.S. & Marinova, S.V. (2005). What predicts skill transfer? An exploratory study of goal orientation, training self-efficacy and organizational supports. *International Journal of Training and Development*, 9 (2), 110-23.
- Clarke, N. (2002). Job/work environment factors influencing training effectiveness within a human service agency: some indicative support for Baldwin and Ford's transfer climate construct. *International Journal of Training and Development*, 6, 146–62.
- Clark, S.C., Dobbins, G.H. & Ladd, R.T. (1993). Exploratory field study of training motivation: influence of involvement, credibility, and transfer climate. *Group & Organization Management*, 18, pp. 292-307.
- Clark, S. C., Dobbins, H. G. & Ladd, T. R. (1993). Exploratory Field Study of Training Motivation. *Group & Organization Management*, 18, 3, 292–307.
- Colquitt, J. A., LePine, J. A. & Noe, R. A. (2000). Toward an integrative theory of training motivation: A meta-analytic path analysis of 20 years of research. *Journal of Applied Psychology*, 85, 679–707.
- Dean, P. J., Dean, M. R. & Rebalsky, R. M. (1996). Employee perceptions of workplace factor that will most improve their performance. *Performance Improvement Quarterly*, 9, 75–89.
- Drucker, P.F. (1999). *Managing oneself*. *Harvard Business Review*, 77, March - April, pp. 65-74.
- Drucker, P.F., Dyson, E., Handy, C., Saffo, P. & Senge, P.M. (1997). Looking ahead:

- implications of the present. *Harvard Business Review*, 75, September-October, 3-10.
- Facteau, J.D., Dobbins, G.H., Russell, J.E.A., Ladd, R.T. & Kudisch, J.D. (1995). The influence of general perception of the training environment on pre-training motivation and perceived training transfer. *Journal of Management*, 21 (1), 1-25.
- Gilpin-Jackson, Y. & Bushe, G. R. (2007). Leadership development training transfer: a case study of post-training determinants. *Journal of Management Development*, 26, 980– 1004.
- Goldstein, I. & Ford, J.K. (2002), Training in Organization. 4th ed., Wadsworth, Belmont, CA.
- Gregoire, T.K., Propp, J. & Poertner, J. (1998). The supervisor role in the transfer of training. *Administration in Social Work*, 22 (1), 1-18
- Grossman, R. & Salas, E. (2011). The transfer of training: what really matters?. *International Journal of Training and Development*, 15(2), 103-120.
- Gumuseli, A.L. & Ergin, B. (2002). The manager role in enhancing the transfer of training: a Turkish case study. *International Journal of Training and Development*, 6 (2), 80-97.
- Hatala, J. & Fleming, P.R. (2007). Making transfer climate visible: utilizing social network analysis to facilitate the transfer of training. *Human Resource Development Review*, 6 (1), 33-63.
- Hawley, J.D. & Barnard, J.K. (2005). Work environment characteristics and implications for training transfer: a case study of the nuclear power industry. *Human Resource Development International*, 8 (1), 65-80.
- Heathfield, S.M. (2009). Training: your investment in people development and retention”, About.com: Human Resources, available at: [http://humanresources.about.com/od/educationgeneral/a/training\\_invest.htm](http://humanresources.about.com/od/educationgeneral/a/training_invest.htm) (accessed 27 September 2009).
- Holton, E. F., III & Baldwin, T. T. (2003), Improving learning transfer in organizations. San Francisco, CA: Jossey-Bass/Pfeiffer.
- Holton, E. F., III, Baldwin, T. T. & Naquin, S. S. (2000). Managing and changing learning transfer systems. in R. A. Swanson (ed.), *Advances in Developing Human Resources*, 8. (The Academy of Human Resource Development & Berrett-Koehler Communications, Inc.
- Holton, E.F. III (1996). The flawed four-level evaluation model. *Human Resource Development Quarterly*, 7 (1), 5–21.
- Jones, G.R. (1986). Socialization tactics, self-efficacy, and newcomers' adjustments to organizations. *Academy of Management Journal*, 29(2), 262-279.
- Kauffeld, S. & Lehmann-Willenbrock, N. (2010). Sales training: effects of spaced

- practice and training transfer. *Journal of European Industrial Training*, 34 (1), 23-37.
- Kirwan, C. & Birchall, D. (2006). Transfer of learning from management development programmes: testing the Holton model. *International Journal of Training and Development*, 10(4), 252-68
- Kontoghiorghes, C. (2001). Factors affecting training effectiveness in the context of the introduction of new technology- a US case study. *International Journal of Training and Development*, 5 (4), pp. 248-60.
- Kueng, P. (2000) Process performance measurement system: a tool to support process-based organizations. *Total quality management*, 11, 67-85.
- Liebermann, S. & Hoffmann, S. (2008).The impact of practical relevance on training transfer: evidence from a service quality training program for German bank clerks. *International Journal of Training and Development*, 12(2), 74-86.
- Lim, D. H. & Johnson, S. D. (2002). Trainee perception of factors that influence learning transfer. *International Journal of Training and Development*, 6, 36–48.
- Montesino, M. (2002). Strategic alignment of training, transfer-enhancing behaviors, and training usage: a post-training study. *Human Resource Development Quarterly*, 13, 89–108.
- Nijman, D.-J.J.M., Nijhof, W.J., Wognum, A.A.M. (Ida) & Veldkamp, B.P. (2006). Exploring differential effects of supervisor support on transfer of training. *Journal of European Industrial Training*, 30 (7), 529-49.
- Noe, R.A. (1986). Trainee attributes and attitudes: neglected influences on training effectiveness. *Academy of Management Review*, 11, 736-49.
- Noe, R. A., Hollenbeck, J. R., Gerhart, B. & Wright, P. M. (2006), *Human Resource Management: Gaining a Competitive Advantage*, 6th edn (Boston, MA: McGraw-Hill Irwin).
- Rouiller, J.Z. & Goldstein, I.L. (1993). The relationship between organizational transfer climate and positive transfer of training. *Human Resource Development Quarterly*, 4 (4), 377-90.
- Shad, I. (2008). Influence of Organizational Work Environment on Transfer of Training in Banking Sector (Doctoral dissertation, NATIONAL UNIVERSITY OF MODERN LANGUAGES).
- Salas, E. & Stagl, K. C. (2009). Design Training Systematically and Follow the Science of Training', in E. Locke (ed.), *Handbook of Principles of Organizational Behavior: Indispensable Knowledge for Evidence-Based Management*, 2nd edn (Chichester: John Wiley & Sons), 59–84.
- Salas, E., Wilson, K., Priest, H. & Guthrie, J. (2006). Design, Delivery, and Evaluation of Training Systems.in G. Salvendy (ed.), *Handbook of Human Factors and Ergonomics*, 3rd edn (Hoboken, NJ: John Wiley & Sons), 472–512.

- Tracey, J. B., Tannenbaum, S. I. & Kavanagh, M. J. (1995). Applying trained skills on the job: the importance of the work environment. *Journal of Applied Psychology*, 80, 239–52.
- Tracey, J. B. & Tews, M. J. (2005). Construct validity of a general training climate scale. *Organizational Research Methods*, 8, 353–74.
- Tracey, J.B., Tannenbaum, S.I. & Mathieu, J.E. (1997).The influence of individual characteristics and the work environment on varying level of training outcomes. *Academy of Management Proceedings*, pp. 210.
- Van Buren, M. E. & Erskine, W. (2002), The 2002 ASTD state of the industry report. Alexandria, VA: American Society of Training and Development.
- Velada, R. & Caetano, A. (2007). Training transfer: the mediating role of perception of learning. *Journal of European Industrial Training*, 31, 283–96.
- Velada, R., Caetano,A.,Michel, J.W., Lyons, B.D. & Kavanagh ,M.J. (2007).The effects of training design, individual characteristics and work environment on transfer of training. *International Journal of Training and Development*, 11(4),282-294
- Vroom, V.H. (1964). *Work Motivation*. New York, NY: John Wiley & Sons.